

## PRESEP AIR SEPARATOR LTR

- High efficiency
- Low costs of operation and maintenance
- High operating reliability
- High sharpness of separation
- High capacity

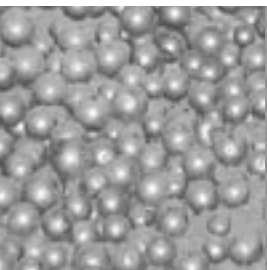



*Air separator LTR-R 1650 at a coke grinding plant with 12.5t/h capacity – OKD Ostrava, Czech Republic*



*Air separator LTR-R*

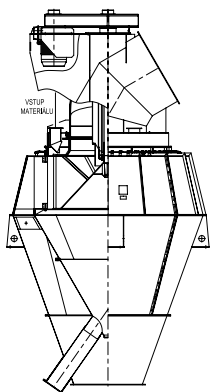

*Air separator LTR-M*

### Separator application

The PRESEP air separator LTR designed by PSP Engineering is a dynamic air separator used in circulating pneumatic grinding plants in combination with a ball mill.

### Characteristics of the PRESEP air separator LTR

- High efficiency and sharpness of separation
- The Tromps curve with a bypass lower than 10% and great steepness guarantees high output and efficiency of separation
- Energy savings of the grinding line with a fineness of separation up to 40%
- Compact structure means less weight and built up space
- Low cost of installation
- Wear parts are effectively protected against abrasion and can be easily replaced
- Negligible maintenance
- Suitable for abrasive material
- Sorted material can be effectively dried and cooled
- Separate a greater range of grain sizes from 20 – 300 µm
- Adjust grain size distribution during operation
- Improved grain size distribution of raw meal
- Favorable conditions for the burning process

### Design of the LTR separator

The separator LTR is used in circulation pneumatic grinding plants, in which the ground material is discharged from the mill by air flow. The separator consists of an outside conical chamber, an inside conical chamber, an upper part connected to the discharge piping, distribution blades, and a rotor with seating and a drive.

The discharge method is a determining factor in the design of the LTR separator. The air separator discharges the product from the inner conical chamber or from the common discharge. The following models can be designed for either method of discharge:

- LTR-R – widest range of application
- LTR-U – for explosive materials
- LTR-M – with an additional upper material inlet

In the LTR-M a portion of the separated material can be directed to the upper inlets to the distribution plate. The material passes through the space between the conical chambers where the coarsest particles are separated as a result of a decrease in gas velocity. These particles are returned to the mill from the inner chamber.

The flow of air carries the material toward the upper part of the separator where the distribution blades and the rotor are positioned.

The angle of the stationary blades controls the speed of the air flow to the rotor and reduces turbulence at the inlet of the rotor.

The rotor consists of a cage consisting of blades. The speed of the rotor is regulated as a function of the properties or size of the desired product fineness. The fine portion of material is carried through the rotor by airflow to the discharge pipes and into cyclones or filters for final separation.

The coarse particles do not pass through the rotor blades and, as a result of the centrifugal force/ gravity, fall into the inner conical chamber from which they are discharged.

The rotor is fixed on the shaft, which is seated on antifriction bearings and mounted in the upper part of the separator. The rotor is either direct or V-belt driven.

# PRESEP air separator LTR

Version A: Discharge from the inner conical chamber

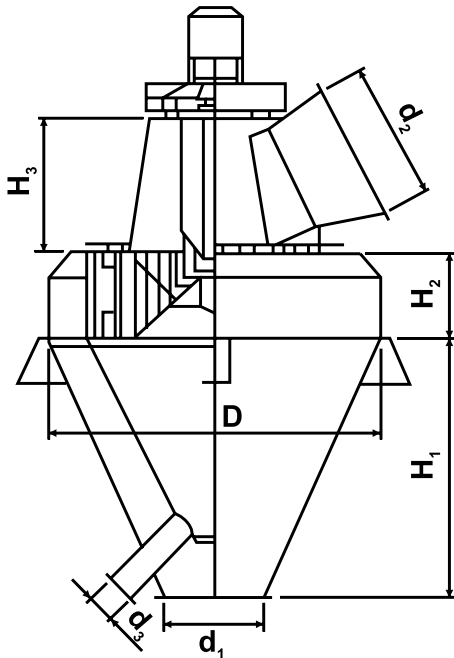

Version B: Common discharge from the inner and outer conical chamber

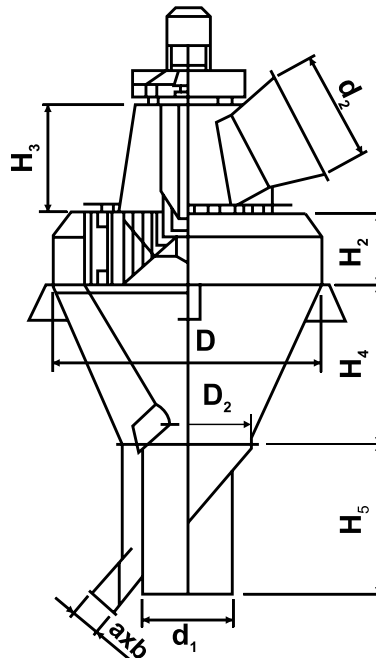

Air separator LTR-R 1650 at the coke grinding plant with 12.5t/h capacity – OKD Ostrava, Czech Republic

Dimensions of PRESEP air separators LTR

Type	D	d <sub>1</sub>	d <sub>2</sub>	d <sub>3</sub>	H <sub>1</sub>	H <sub>2</sub>	H <sub>3</sub>	H <sub>4</sub>	H <sub>5</sub>	D <sub>3</sub>	a x b
	mm	mm	mm	mm	mm	mm	mm	mm	mm	mm	mm
LTR 580	1210	410	410	155	1010	300	600	980	850	780	120 x 160
LTR 720	1500	450	450	220	1750	450	630	1000	880	800	160 x 200
LTR 820	1700	500	520	220	1600	450	630	1020	935	820	160 x 200
LTR 900	1900	550	580	220	1600	450	650	1120	980	900	200 x 250
LTR 1000	2100	600	650	220	1700	530	810	1250	1400	980	200 x 250
LTR 1100	2250	700	700	250	1920	600	900	1350	1400	1085	250 x 320
LTR 1250	2370	750	750	250	2220	680	900	1440	1400	1160	250 x 320
LTR 1400	2550	800	800	275	2280	780	1250	1580	1440	1260	250 x 320
LTR 1500	2750	850	850	275	2350	870	1300	1710	1560	1370	250 x 320
LTR 1650	2980	1000	1000	275	2710	950	1400	1800	1650	1500	250 x 320
LTR 1850	3330	1140	1140	355	2800	980	1400	2000	2000	1700	320 x 400
LTR 2000	3550	1200	1250	355	2850	1030	1300	2000	2400	1900	320 x 400
LTR 2100	3720	1250	1300	400	2960	1080	1300	2400	2330	2130	400 x 500
LTR 2350	4100	1400	1450	400	3400	1180	1600	2500	2420	2180	400 x 500
LTR 2500	4380	1600	1600	400	3800	1400	1700	2630	2480	2200	400 x 500
LTR 2700	4700	1700	1800	450	4200	1470	1600	2770	2540	2230	400 x 500
LTR 3000	5100	1850	1900	450	4200	1520	2050	3060	2800	2460	400 x 500
LTR 3250	5500	2000	2000	500	4200	1580	2300	3300	3020	2650	400 x 500
LTR 3650	6150	2200	2300	500	4500	1700	2500	3680	3370	2960	400 x 500

## Capacity of the LTR separators

Type	Gas flow rate at the inlet velocity		Motor power input at the peripheral velocity 25 m/s	Capacity
	20 m/s	16 m/s		
	m <sup>3</sup> /h	m <sup>3</sup> /h	kW	t/h*
LTR 580	9505	7605	5.0	5
LTR 720	11,135	8910	7.5	8
LTR 820	13,680	10,945	9.0	10
LTR 900	16,635	13,310	11.0	12
LTR 1000	20,385	16,305	13.5	15
LTR 1100	24,815	19,850	16.5	18
LTR 1250	31,875	25,500	21.0	23
LTR 1400	40,015	32,010	26.5	29
LTR 1500	46,100	36,880	30.5	34
LTR 1650	55,680	44,540	36.5	40
LTR 1850	69,905	55,925	46.0	50
LTR 2000	81,660	65,325	53.5	60
LTR 2100	90,290	72,230	59.5	66
LTR 2350	113,135	90,505	74.5	83
LTR 2500	127,910	102,325	84.0	93
LTR 2700	149,110	119,290	98.0	110
LTR 3000	183,720	146,980	120.5	135
LTR 3250	215,735	172,585	142.5	160
LTR 3650	272,230	217,785	180.0	200

\* Related to the cement material of the fineness 12-14% R 0.09 mm



Air separator LTR-R 1650 at the coke grinding plant with 12.5 t/h capacity – OKD Ostrava, Czech Republic



Air separator LTR-R 2000 at a lime grinding plant with 36 t/h capacity – Vitošov, Czech Republic

## Reference list of the LTR separators

Year	Country	Locality	Customer	Qty.	Type	Capacity	Material	Grinding fineness	Mill dimensions
				pc		t/h			m
2005	Germany	Freiberg	Koeppern	1	LTRR 400	5	diverse	0 – 0,2 mm	
2003	Czech Rep.	Teplice	Fluorit	1	LTRR 1000	3.5	feldspar	2% R63	2.2 x 6
2002	Bosnia	Lukavac	FCL	1	LTRR 2700	75	cem. mat	14% R90	3.8 x 7.8
2002	China	Lanzhou	Gansu H. E.	1	LTRR 1500	6	limenite	15% R40	2.8 x 5.4
2002	Spain	Arrigoriaga	Italcementi	1	LTRR 2500	105	cem. mat	20% R 90	3.4 x 12
2001	Ukraine	IvanoFrankovsk	Ivanofrankovsk cement	1	LTRR 720	7	gypsum	5% R 80	
2000	Brazil	Itapicuru	Santos GIJS	1	LTRR 2100	80	cem. mat	12% R 90	3.4 x 6.6
2000	Czech Rep.	Poběžovice	CHKZJ Chlumčany	1	LTRR 720	6	feldspar	20% R 90	
2000	Czech Rep.	Ostrava	OKD Ostrava	1	LTRR 1650	12.5	coke	20% R 90	3.4 x 7
1999	Italy	Sesto Campano	Colacem	1	LTRU 1850	27	coal	4% R 90	4.2 x 6
1999	Slovenia	Celje	Cinkarna	1	LTRR1250M	4.5	TiO <sub>2</sub> slag	3,5% R 40	2.6 x 4.5
1998	Slovakia	Horné Srnie	Cemmac	2	LTRR 2000	50	cem. mat	16% R90	3.1 x 6
1997	Czech Rep.	Čížkovice	Lafarge	1	LTRR 580	5	limestone	1% R 90	

LTR separators are used in grinding plants with pneumatic circulation working in closed or open circuit. The product is collected in cyclones or filter. The closed circuit is mainly used when the material is simultaneously dried and the open circuit is used in grinding plants without drying.

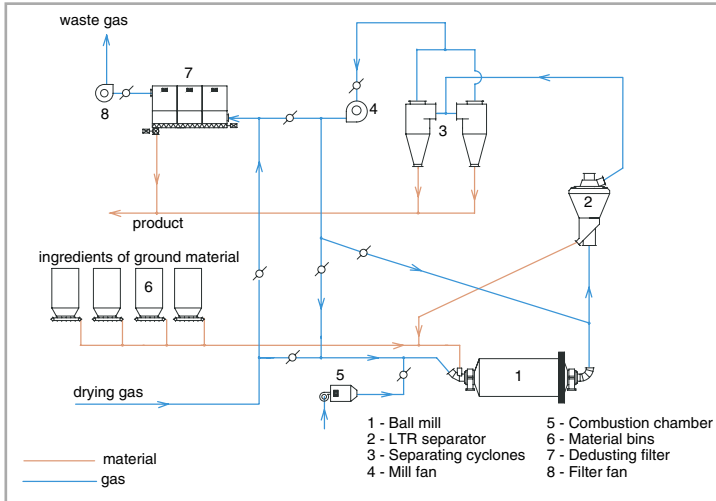

Pneumatic grinding plant with drying closed circuit arrangement with cyclones: This arrangement is used for grinding materials of elevated moisture content and lower required fineness of the finish product.

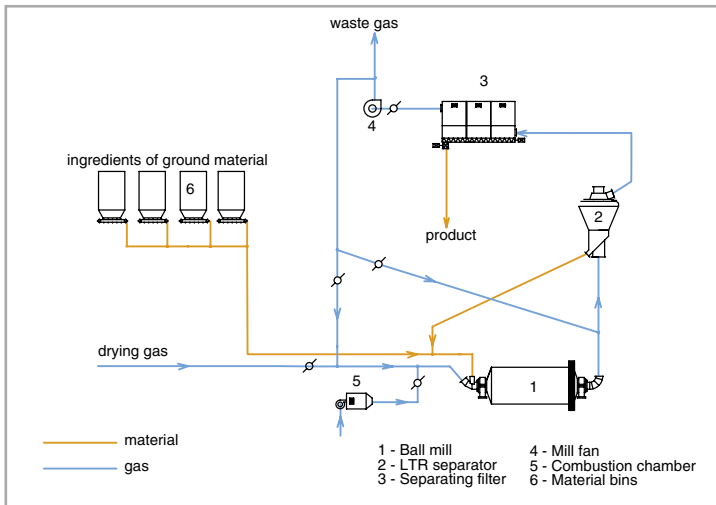

Pneumatic grinding plant with drying in a closed circuit arrangement with filter: This arrangement is used for grinding materials of lower moisture content but higher required fineness of the finish product.

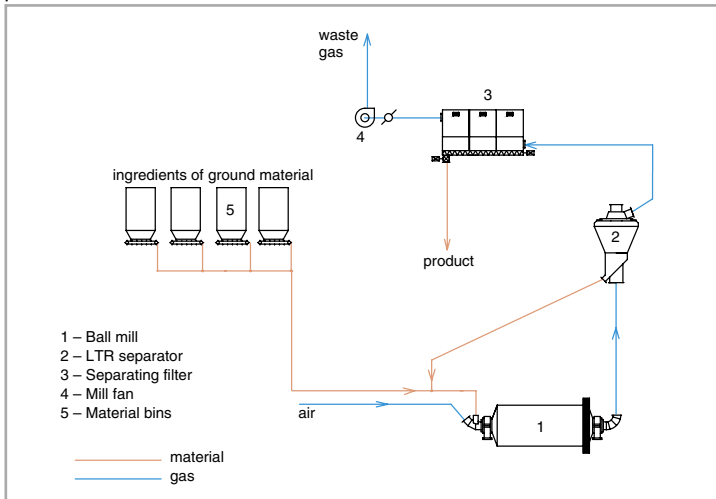

Pneumatic grinding plant without drying in an opened circuit arrangement with filter. This arrangement is used for grinding materials without drying.



Air separator LTR-R 2500 for 105t/h at the cement raw material grinding plant – Rezola, Arrigoriaga, Spain



Air separator LTR-R 2500 at the cement raw material grinding plant with a capacity of 105t/h – Rezola, Arrigoriaga, Spain



Air separator LTR-R 1250M at the TiO<sub>2</sub> slag grinding plant with a capacity of 4.5t/h – Celje, Slovenia



[www.pspengineering.cz](http://www.pspengineering.cz)

PSP Engineering a.s. is a leading supplier of specialized products and entire processing plants for the building material and mineral processing industries. PSP Engineering has been involved in the design and construction of cement plants, lime works, quarry and crushing plants, as well as gravel and sand pits for more than 50 years.

**PSP Engineering a.s.**  
Kojetínská 71, č.p.358  
750 53 Přerov, Czech Republic  
Tel. +420 581 232 604, +420 581 233 396  
Fax +420 581 203 176  
e-mail: [info@pspeng.cz](mailto:info@pspeng.cz)  
[www.pspengineering.cz](http://www.pspengineering.cz)



Data in this brochure serve for the preliminary designing only.  
The producer reserves the right to modify products and/or their parameters without previous notification.  
Grinding systems / PRESEP air separator LTR EN 01/05

© 2005 PSP Engineering a.s.